

Wilkhahn



Contas.



Contas.

The success of training and skills development depends greatly on the facilities that support these processes. Flexible class sizes and methods require tables that can adjust to whatever the room's current demands are. Furthermore, the quality of the furnishings has an impact on the importance attached to personnel and corporate development.

Contas is an intelligent, superior and durable furnishing solution that quickly pays dividends. The clarity and quality of this sophisticated table system's design is impressive. It cuts an equally fine figure in conference rooms and highlights the importance of the occasion. Contas also offers attractive cost benefits in terms of facility management. Contas can adapt to different numbers of participants, course methods and room shapes. Tool-free assembly turns the table systems into single tables, linked rows or grouped into horseshoe shapes or blocks in no time. The patented interlocking mechanism and the clever integration of all functions save time and money. The frame is bright chromium plated, with a choice of laminate and veneer tabletops.





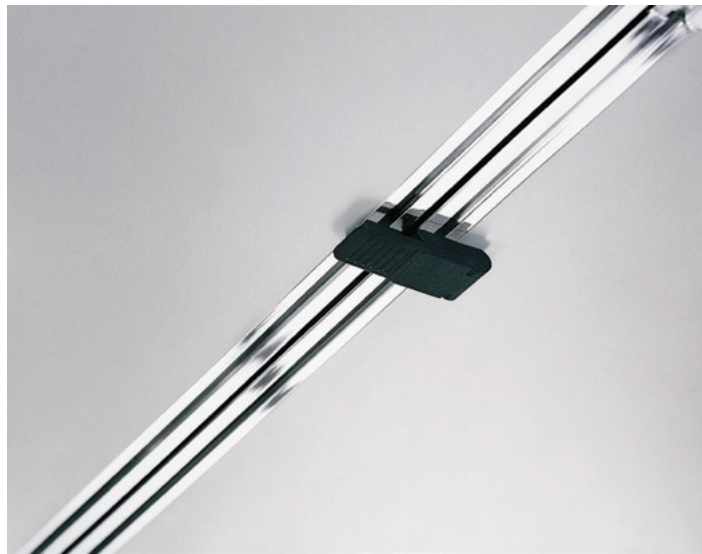

Contas. References.

Models 540/15. Object : The UN's Room XIX plenary chamber, Genf, Photo : Studio PEIA.



Contas. 540 range. Technical details.

Wilkhahn

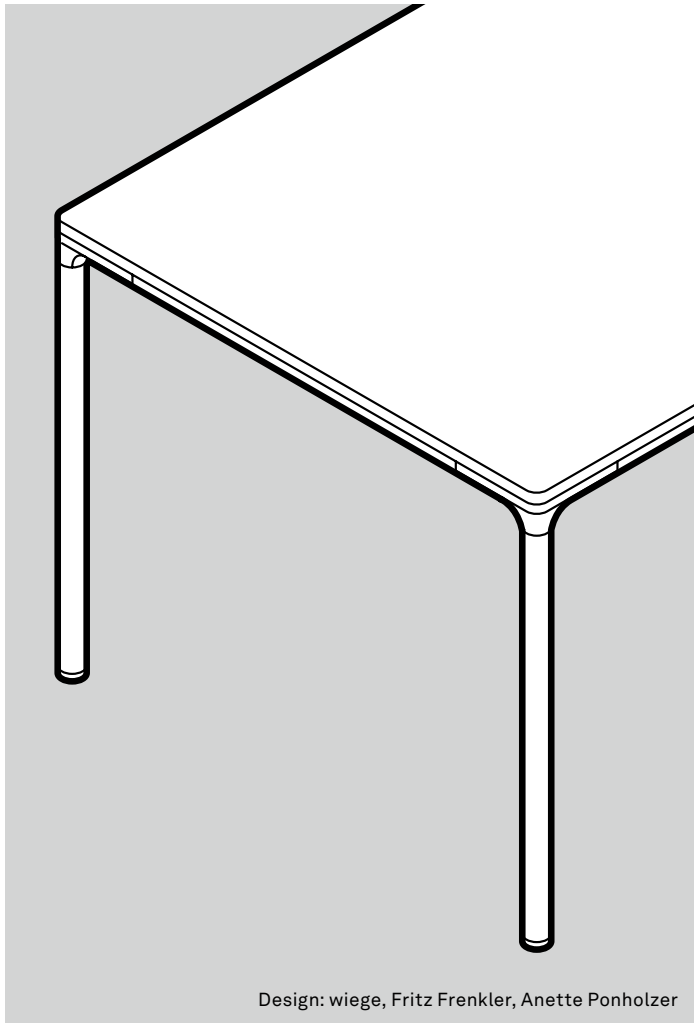

Design: wiege, Fritz Frenkler, Anette Ponholzer

Lightweight and flexible conference table system for multipurpose conference, seminar and training spaces. It consists of standalone tables which are optionally foldable and stackable.

Frame

Bright chrome-plated or coated Ø38 mm round tubing legs. Glides (for folding tables with disc profiles) made of black polyamide for soft flooring (standard) and black polyurethane for hard flooring (please state when ordering). Optionally as a stackable version (integrated separator) with table legs that turn inwards and can be locked in place using a leg retaining clamp integrated in the table top. Leg retaining clamp made of black polyamide. Tables can be fitted with table-table-connectors.

Core material of table top

- Laminboard

Table top group 1 – laminate

- Table top thickness 34 mm

Variant 1

- Single color based on the Wilkhahn color and surface samples
- Beech edging (with a natural oiled finish)

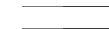

Straight wood edging

Table top group 2 – veneer

- Table top thickness 34 mm

Variant 1

- Oak, knotty oak or heartwood ash veneer from the Wilkhahn wood color-stain samples
- Edging, color-matched as far as possible with the veneer

Variant 2

- Walnut, smoked oak or black walnut veneer with sapwood based on the Wilkhahn wood color-stain samples
- Edging, color-matched as far as possible with the veneer



Straight wood edging

Modesty panels

Aluminum frame, coated with a silver satin finish, covered with anthracite fabric. Black polyamide handles.

Standards

The Contas tables comply with the ANSI/BIFMAX5.5 standard.

Subject to change.

Contas. 540 range. Product types.

Wilkhahn

Table top groups



Laminate, veneer type 1 or 2, soft matt laminate,

Laminate. The material is made by bonding cellulose and décor paper layers, as well as resin, by applying heat and pressure. This produces an extremely tough surface that comes in a variety of different colours. Laminate is highly recommended for areas where the tables are subject to a lot of wear and tear because they are frequently moved around for example.

Wood veneers. Natural wood is a living material: in the way it looks and changes over the years. Sometimes more significantly and sometimes more subtly, depending on the type of wood and how light it is. If a more consistent look is preferred, stained surfaces or industrially produced veneer are available.

Frame versions

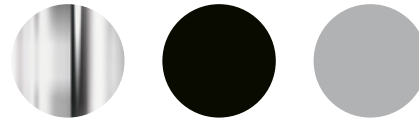

Tubular steel bright chrome plated, black or silver-coated matt satin finish

The digital sample colors differ from the originals.

 You can find all materials and more colors in our material library.

Contas. 540 range. Accessories and other items.

Wilkhahn



The stackable folding-leg tables are fascinating and practical. Place the table with the top face down, turn legs to release, pull up, fold up and snap into the integral retaining clamp. This automatically exposes the separators, which provide a soft, non-slip buffer for stacking purposes.



246/75 Four-wheeled trolley to take five folding tables 540/15 table depth 75 cm (29 1/2")

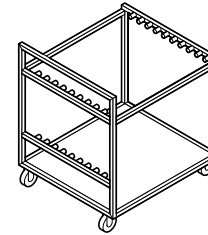

546/90 Four-wheeled trolley to take five folding tables 540/25 table depth 90 cm (35 3/8")

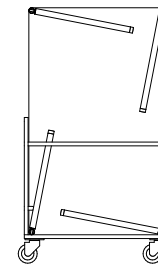
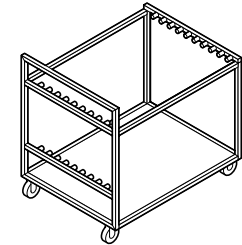

94
37"

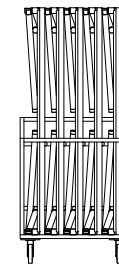

71
28"

94
37"

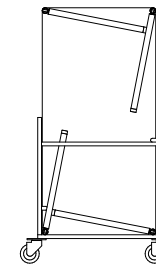

81
31 7/8"

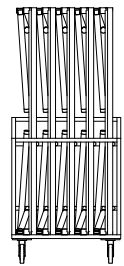

71
28"

94
37"



71
28"

546/90

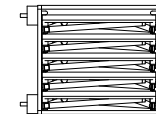

71
28"

546/75

Contas. 540 range. Accessories and other items.

Wilkhahn



549/04 Modesty panel
Length 140 cm (55 1/8"), H 40 (15 3/4"),
for models 540/15 and 540/25

549/05 Modesty panel
Length 170 (66 7/8"), H 40 (15 3/4"),
for models 540/18 and 540/28

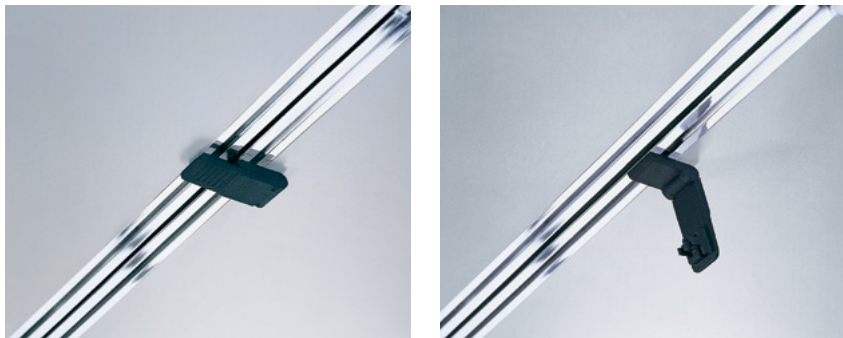
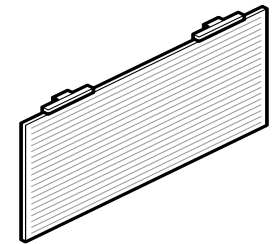

Interlocking connectors, slotted into the frame profiles, permit direct linking of single tables, for example in a block configuration.

549/20 Table-table connector



Contas. 540 range. Models and dimensions.

Wilkhahn

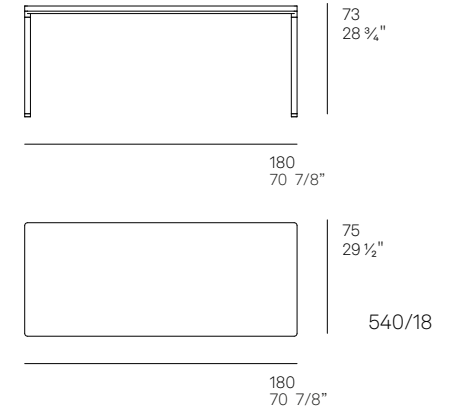
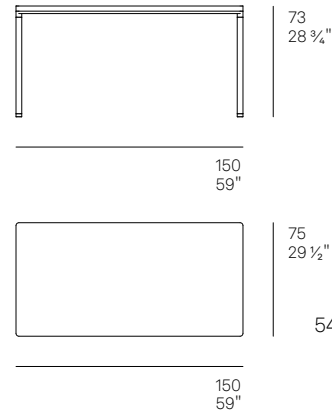
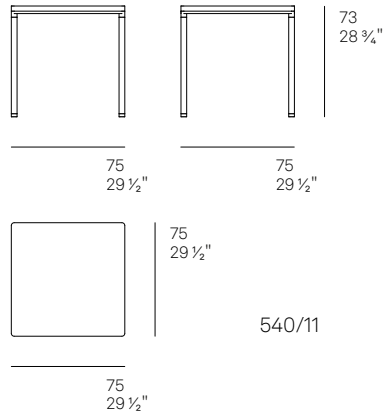
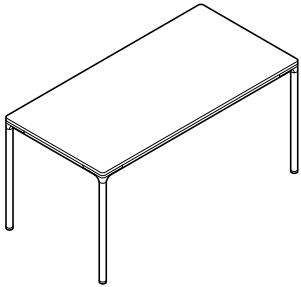
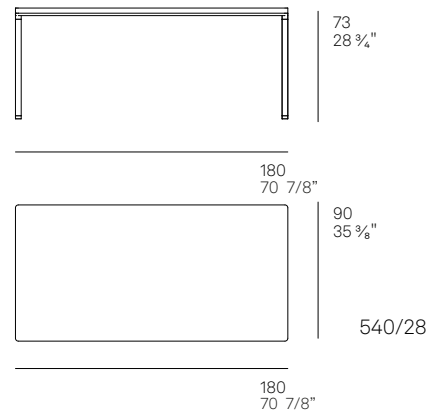
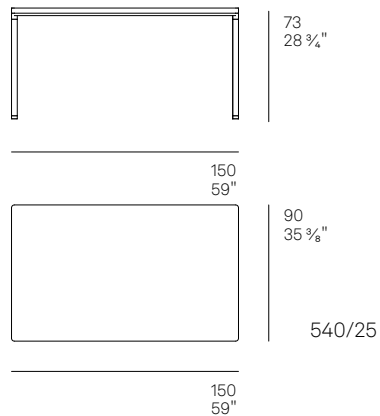
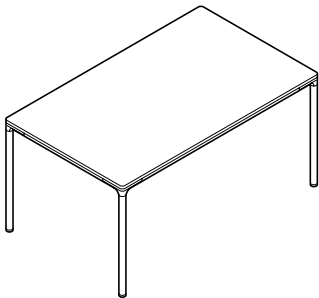
540/11

540/15

Contas. 540 range. Awards / standards / certificates.

Wilkhahn

Awards



Product certificates / product standards



DIN EN 527

Company's certificates, memberships



For further information please contact us.

Wilkhahn



Wilkening + Hahne GmbH+Co.KG

Fritz-Hahne-Str. 8

31848 Bad Münder

Germany

Tel.: +49 5042 999 100

contact@wilkhahn.de

www.wilkhahn.com



Roof of one of the four pavilions,
which were designed by architect
Frei Otto, on the Wilkhahn site.
Photo: Klemens Ortmeier